



The EPIC floating mixer is designed to mix liquids of varying viscosities without entraining atmospheric oxygen. This unique design allows the consultant or owner the option of either up or down pumping action in basins or tanks when liquid level variation is a design condition. The EPIC Floating Mixer is used in alum sludge storage tanks, in SBR or other aeration systems to supplement mixing in neutralization tanks. Although T-304 stainless-steel is standard, EPIC can fabricate your mixer of special 316 L S/S to withstand any corrosive environment.

**Low cost, easy to install, portable, self-supporting, long life, trouble-free operation, and easy to maintain.**

**Dimensions available upon request.**

## FEATURES

- All stainless steel construction
- Rugged, reliable, all domestic fabrication
- Competitive value
- High pumpage efficiency
- Quiet / reversible
- Extended warranty
- Multiple seals
- #316 - L SS available for select applications
- Motor speeds from 720 to 1800 RPM (60 Hz)
- Dual speed motors available
- 50 Hz motors available

## ACCESSORIES

- Directional flow discharge
- Extended volutes
- Rigid mooring arm
- Swivel mooring arm
- Motor space heaters
- Power cable and floats
- Mooring cable
- Full factory wiring
- Controls

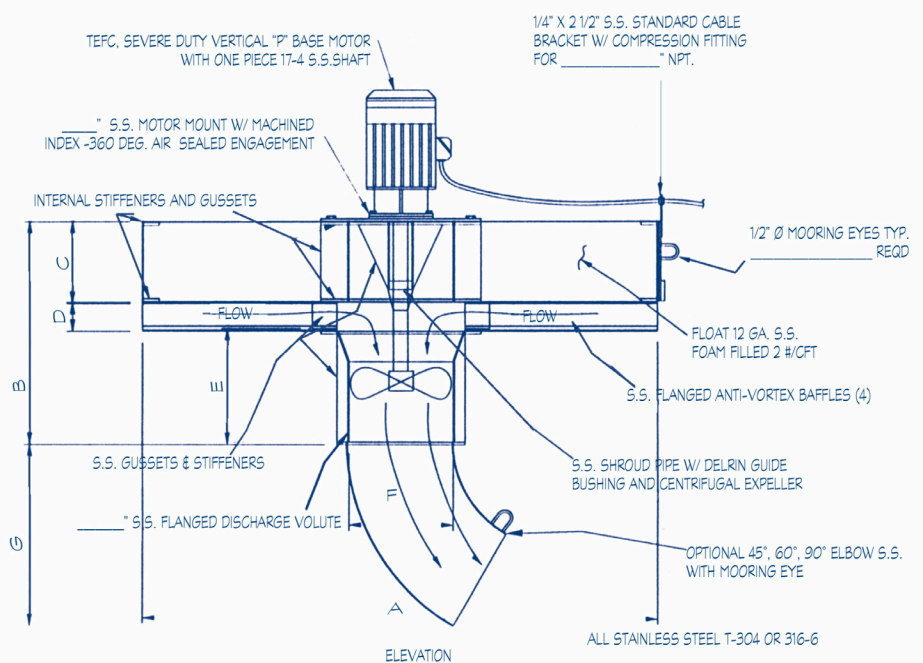

# SPECIFICATIONS: STAINLESS STEEL EPIC INTERNATIONAL FLOATING MIXER

## General

The following specifications cover the performance, design, construction, and installation of the floating mixing equipment.

The contractor shall furnish and install \_\_\_\_\_ EPIC floating mixers complete and operable under normal conditions and in accordance with the plans and specifications. The mixers shall be \_\_\_\_\_ HP at \_\_\_\_\_ RPM.

Each mixer shall be capable of mixing up to \_\_\_\_\_ gallons without introducing air into the contents and shall be capable of short term reversing without the intrusion of water into the motor housing.

## Design

### Motor

The motor shall be designed for down pumping mixer service and shall have the following features:

- Minimum service factor of 1.15 over the motor nameplate at 40°C ambient, TEFC construction, vertical "P" base, severe duty rating.

- Non-hygroscopic windings with class "F" insulation

- One-way condensate drains

- A labyrinth seal shall be one piece, 17-4 ph stainless steel in the 1150 HT condition

The motor shall be designed for down pumping mixer service and shall have the following features:

- Minimum service factor of 1.15 over the motor nameplate at 40°C ambient, TEFC construction, vertical "P" base, severe duty rating.

- Non-hygroscopic windings with class "F" insulation.

- One-way condensate drains.

- A labyrinth seal shall be designed for a minimum life of 5 years at the rated thrust of the unit.

- A stainless steel nameplate showing the voltage, amperage, service factor, insulation type, speed, phase and serial number.

- The motor shaft shall be one piece, 17-4 ph stainless steel in the 1150 HT condition.

- The motor terminal box shall be watertight and shall withstand the pull of the power cable of at least 100 lbs.

### Flotation

- The float shall be unitized construction of minimum 12 gauge type #304 stainless steel and shall have a minimum of three (3) internal bulkheads.

- Certified welders in accordance with QW 484 of Section IX, ASME boiler and pressure vessel code shall perform all welding. All 12 gauge welds shall be against internal structural chain plate back-ups. Mooring eyes shall be purpose made, double shank, marine grade stainless steel and shall be attached to structural members only. Welding to the outer float skin only or to back-up plates welded to the out skin only will not be allowed. Minimum flotation service factor shall be 1.7 times the unit weight.

### Throat / Volute

- The throat / volute assembly shall be a separate, removable assembly and shall not be fabricated integral with a float assembly. The volute / throat wall thickness shall be a minimum 3/16" and shall be fabricated from T-304 stainless steel.

### Motor Mounting

- The motor shall be mounted to the float / volute assembly via a flange to flange indexed fit that shall permit removal of the motor / propeller unit without disturbing or removing the volute assembly from the float.

### Propeller

- The propeller shall be two blade, anti-fouling type, precision cast of ( ) stainless steel; ( ) manganese bronze; ( ) nibral.

- The propeller shall be dynamically and hydraulically balanced to 2 mil peak to peak at the rated motor speed.

- The propeller shall direct the discharge from near the surface downward.

### Stability

- The float diameter shall exceed the float mixer height by a factor of 1.38 or more to assure stability under all operating conditions.

### Vibration

- Each mixer shall be tested for vibration after assembly with an allowable maximum not to exceed 2 mils peak to peak measured at the motor bearings and at a frequency equal to the motor speed times the number of blades on the propeller.

### Location and Mooring

- Each mixer shall be located as shown on the plans.

- Each mixer shall be provided with \_\_\_\_\_ diameter mooring cable.

- Each mixer shall be provided with \_\_\_\_\_ mooring eyes.

- Mooring hardware shall be stainless steel of sufficient size to accommodate the cable diameter specified.

- Each mooring line shall be tightened such that the mixer is free from lateral movement but can move vertically \_\_\_\_\_ feet.

### Power Cable

- The power cable shall be AWG \_\_\_\_\_ 3 conductor plus ground, insulated neoprene jacketed for underwater use.

### Power Cable Floats

- Power cable floats shall be provided every \_\_\_\_\_ feet and shall be of such size as to prevent strain on the motor terminal to electrical connection at the basin wall.

### Power Cable Support Bracket

- A stainless steel power cable support bracket shall be provided with compression fittings to act as a strain relief and to prevent the power cable from chaffing on the mixer float.

### Manufacturer

- The mixers, mooring systems, hardware, power cable, power cable floats shall be as manufactured by EPIC INTERNATIONAL, INC. with general offices in Ashland, Virginia.

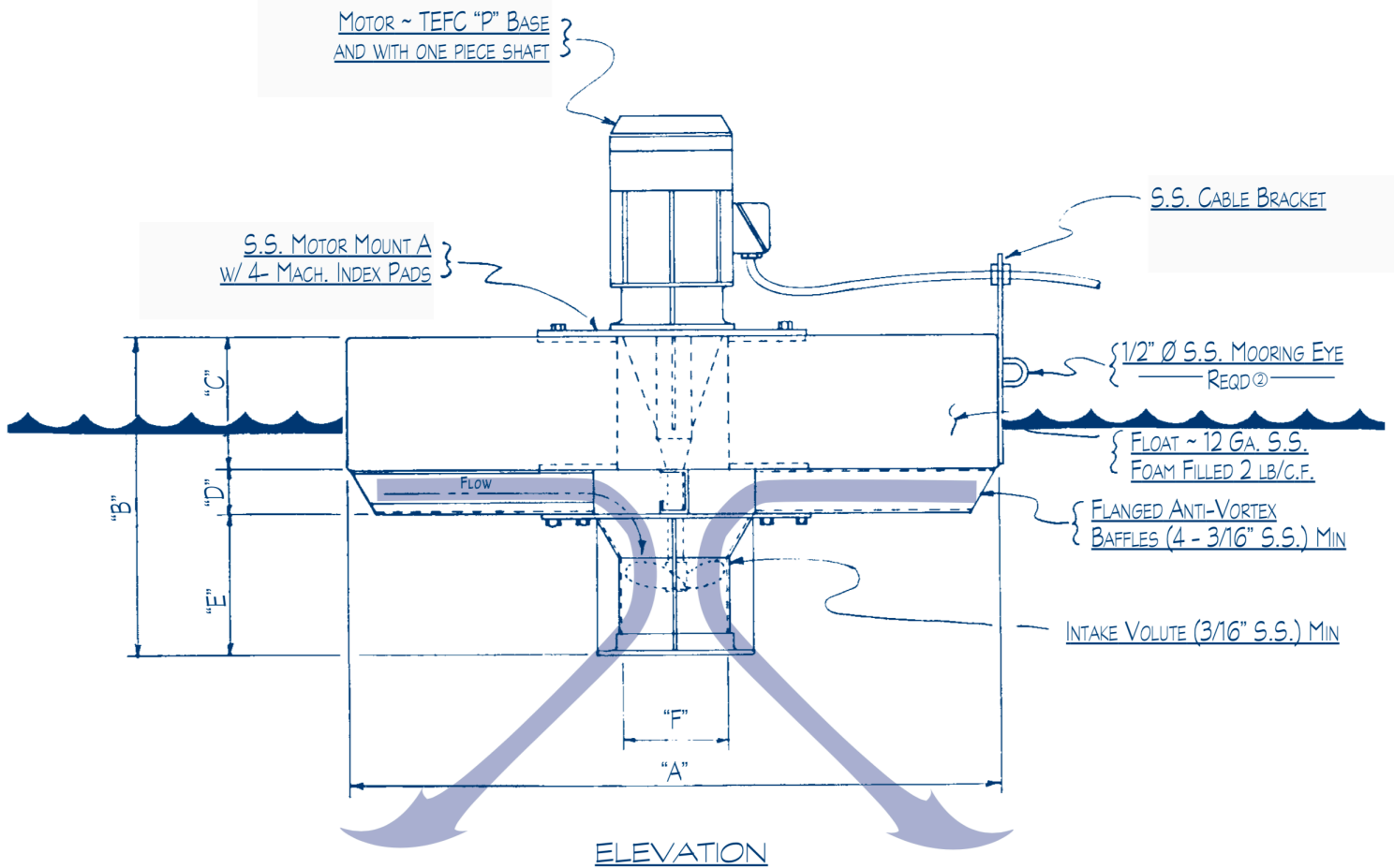

## PARTIAL INSTALLATION LIST

- Calhoun, GA
- Lajas, PR
- National Dye Works, SC
- New Brunswick Electric Power, Canada
- Rowland, NC
- Hondo, TX
- Washington Beef, Co.
- Minette Mills, NC
- Cleveland, OK
- Louisburg, NC
- Pahokee, FL
- Prosser, WA
- Koon Chon, Hong Kong
- Wendell, NC
- Manteca, CA
- Richmond, VA
- Amiss, LA
- Kimberly-Clark
- Samsung Engineering
- Speedway, IN
- Pass Christian, MS
- Hardington, NE
- Middleville, MI
- Kitsap, WA

## Environmental Products for Innovative Conservation

Screw Pumps · Aerators · Mixers · Flight Decks

115 Hanover Avenue, Suite 2  
Ashland, Virginia 23005 USA  
epicintl.com  
try@epicintl.com  
Phone: 804.798.3939