

EPIC AERATORS

BUILT ON THESE PRINCIPLES....

1 Performance and Durability

EPIC Aerators are designed with performance and durability in mind. The EPIC structural components provide both strength and enhanced performance.

2 Construction with a Purpose

The unique "C" shaped radial beam construction stiffens the unit and distributes the operating loads while providing hydraulic channeling of the pumped liquid.

3 Serviceability

Difficult to reach below water cross vane stabilizers are not needed, thus eliminating underwater catch points for debris.

The swirling mass of liquid is straightened as it exits from the deflector, changing the trajectory of the liquid to a flatter dispersion pattern. This lower trajectory reduces aerosols and misting. The radial beams act to deflect the rotational forces of the emerging liquid, resulting in a stable float.

EPIC AERATOR FEATURES AND YOUR BENEFITS

Sturdy, all stainless steel construction with no concentrated load points.

The float construction has no potential leaking points caused by bolt or other penetrations through the stainless steel skin.

No structural castings with the potential for hidden gas and sand hole porosity, resulting in stress concentrations and unexpected imbalance.

Internal hardpoints which reinforce and stiffen the float and the volute tube.

Welded in accordance with requirements of AWS standards.

Radial C-beam for load distribution, rigid construction, and improved liquid dispersion.

316-L Stainless Steel, dynamically balanced, weedless propellers.

Floats are injection filled with 2.25 to 2.50 pcf density closed cell polyurethane foam.

Standard stand-off power cable support bracket.

100% reserve buoyancy factor is standard.



SPECIFICATIONS

1. General

- 1.1 The following specifications cover the performance, design, construction, and installation of the floating aeration equipment.
- 1.2 The contractor shall furnish and install _____ EPIC floating aerators, complete and operable under normal conditions and in accordance with the plans and specifications.
Horsepower _____
RPM _____
GPM _____
EPIC Model No. _____

2. Performance

- 2.1 Each aerator shall be capable of transferring a minimum of _____ lbs. of oxygen per name plate horsepower per hour under standard conditions of zero dissolved oxygen at sea level; 20°C; alpha and beta = 1.0.

3. Design

- 3.1 Motor: The motor shall be designed for aerator service and shall have the following features:
 - 3.1.1 Minimum service factor of 1.15 over the motor name plate at 40°C ambient
 - 3.1.2 TEFC construction, vertical "P" base, severe duty rating
 - 3.1.3 Non-hygroscopic windings with class "F" insulation
 - 3.1.4 One-way condensate drain
 - 3.1.5 A labyrinth seal shall be provided below the lower bearing to prevent water migration up the motor shaft.
 - 3.1.6 The lower bearing shall be designed for a minimum life of 5 years at the rated thrust of the unit.
 - 3.1.7 A stainless steel name plate showing the voltage, amperage, service factor, insulation, type, speed, phase and serial number
 - 3.1.8 The motor shaft shall be one piece, 17-4 PH stainless in the 1150 HT condition
 - 3.1.9 The motor terminal box shall be water tight and shall withstand the pull of the power cable of at least 100 lb.
- 3.2 Flotation: The float shall be utilized construction of minimum 14 gauge type T-304 stainless steel and shall have a minimum of three (3) internal bulkheads. All welding shall be performed by certified welders in accordance with QW-484 of Section IX, ASME Boiler and Pressure Vessel Code. All 14 gauge welds shall be against internal structural chain plate back-ups. Mooring eyes shall be purpose made double shank, marine grade stainless steel and shall be attached to structural members only. Welding to the outer float skin only will not be allowed. Flotation service factor shall be 17 X unit weight.
- 3.3 Volute and intake cone: The volute and intake cone shall be constructed integrally with the float and shall be of the same material and standard as the float, but shall be a minimum 3/16" T-304 stainless steel plate, precision rolled with no members which could cause obstruction or clogging to the unit. The volute and intake cone shall be properly reinforced with the external gussets to support the weight of the complete aerator during shipment and handling.

- 3.4 Diffuser/motor mounting: The diffuser motor mounting shall be a machined stainless steel, raised segmented flange to receive the "P" base of the motor flange, a cast stainless steel diffuser cone and shaft shroud with a non-contact lower Derlin guide bearing. A machined Derlin trash slinger-impeller shall be attached to the motor shaft extension and direct any stringy material away from the motor shaft and shroud. Motor mounting bases that do not provide support for the external motor shaft will not be allowed. The torque developed by the motor shall be transmitted through the diffuser/motor mounting assembly to the float via stainless steel means welded to the volute inner ring, the outer flat perimeter and the float surface. No point loading will be permitted.
- 3.5 Propeller: The propeller shall be two blade, anti-fouling type, precision cast of _____ and dynamically balanced to 2 mil peak to peak when attached to the motor shaft and assembled to the diffuser/motor mount and operated at the intended motor speed as measured by Balance Technology Vibropac #1 vibration recorder.
- 3.6 Stability: The float diameter shall exceed the total aerator height by a factor of 1.38 or more to assure stability under all operating conditions.
- 3.7 Vibration: Each aerator shall be tested for vibration after assembly with an allowable maximum not to exceed 2 mils to peak measured at the motor bearings and at a frequency equal to the motor speed times the number of blades on the propeller.

4. Location and Mooring

- 4.1 Each aerator shall be located as shown on the plans
 - 4.1.1 The aerators shall be moored with _____ diameter mooring line.
 - 4.1.2 The aerators shall be provided with _____ point mooring eyes
 - 4.1.3 Mooring hardware shall be stainless steel of sufficient size to accommodate the cable diameter specified.
 - 4.1.4 Each mooring line shall be tightened such that the aerator is free from lateral movement but can move vertically _____ feet.

5. Power Cable

- 5.1 The power cable shall be AWG _____ 3 conductor plus ground insulated neoprene jacketed for underwater use.

6. Power Cable Floats

- 6.1 Power cable floats shall be provided every _____ feet and shall be of such size as to prevent strain on the motor terminal or the electrical connection at the basin wall.

7. Manufacturer

- 7.1 The aerators, mooring system, hardware, power cable and power cable floats shall be as manufactured by EPIC INTERNATIONAL, INC. with general offices in Ashland, Virginia, U.S.A.

FEATURES & COMPONENTS

EPIC Aerators are built from tough, corrosion-resistant stainless steel. The volute is reinforced and stiffened by horizontal and vertical plates. All components are welded in accordance with AWS standards.

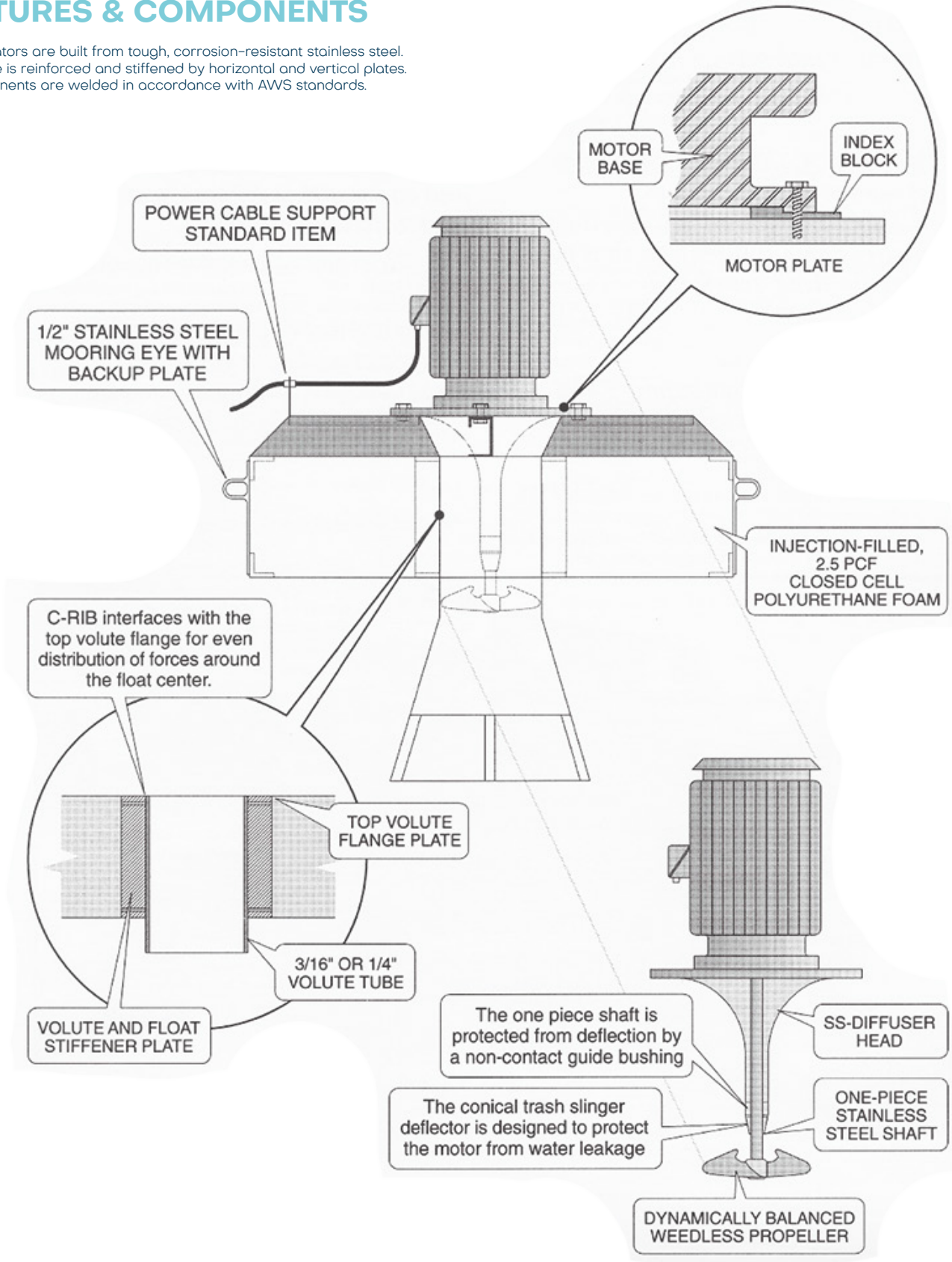

OPTIONS

50 HZ motors	Factory wiring of power cable
Anti-erosion attachment	Controls
Extended volutes	Mooring cable and hardware
Anti-ice heaters	Dual speed motors
Anti-condensation motor heaters	#316-L stainless steel
Radial arm mooring	Explosion-proof motors
Swivel arm mooring	

OUR INSTALLATIONS AND CUSTOMERS

Ada Beef	Deltona Utilities, FL	Lenox, IA	SanFaTex Textiles
ADM, Netherlands	Des Plains, IL	Lubbock, TX	Santa Rosa, CA
Appomattox, VA	Domain Winery, CA	Mineral Wells, TX	Shasta Beverage Company
Braselton, GA	Douglas County, GA	Mobridge, SD	Springfield, OH
Cagles Poultry	Erwin, NC	Mount Washington, KY	Susanville, GA
Caldwell Housing, LA	Fallbrook, CA	National Guard, Puerto Rico	United States Air Force
Calhoun, GA	Fina Oil, TX	New Brunswick Power, Canada	United States Navy
Calipatria State Prison, CA	Forestville, NY	Newnan, GA	VanBuren, AR
Calistoga, CA	Fort A. P. Hill, VA	North Charleston, SC	Victor Preserving, NY
Cavanish Farms, Canada	Fort Hood, TX	Oyster Bay, NY	Wauseon, OH
Cave City, AR	Griffen, GA	Passaic Valley, NJ	West Columbia, TX
Chelsea, MI	Havana, FL	Rincon, GA	Williamston, MI
China Shipbuilding, Republic of China	Hope Mills, NC	Rowland, NC	York, PA
Coachella, CA	ICI Americas	Rutherford Winery, CA	Zionsville, IN
Columbus, MS	Iowa City, IA	Saint George, UT	
Dallas Center, LA	Jefferson, GA	Salt Lake City, UT	
	LeRoy, NY		

Environmental Products for Innovative Conservation

Screw Pumps · Aerators · Mixers · Flight Decks

115 Hanover Avenue, Suite 2
Ashland, Virginia 23005 USA
epicintl.com
try@epicintl.com
Phone: 804.798.3939

MODELS AND DIMENSIONS

Motors

Cast iron frame, severe chemical duty, TEFC, aerator motor

Oversized stainless steel shafts

B-10, 100,000 hour high thrust oversized bearings

Non-hygroscopic copper windings

Class "F" insulation

1.15 service factor at 40° C ambient

Labyrinth seals

Stainless steel motor mounting with machined flanges

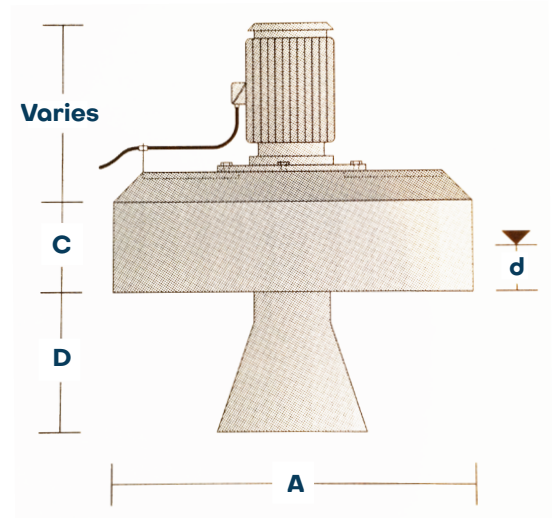

SS MODEL	SIZE HP	RPM	DIMENSIONS (inches)				APPROX. WEIGHT (lbs)
			A	C	D	d	
1-1800	1	1800	48	12	10	5	352
2-1800	2	1800	48	12	10	5	352
3-1800	3	1800	48	12	10	5	352
5-1800	5	1800	60	12	10	6	602
7.5-1800	7.5	1800	60	12	10	6	602
10-1800	10	1800	60	12	10	6	602
15-1800	15	1800	72	12	12	6	870
20-1800	20	1800	72	12	12	6	870
25-1800	25	1800	72	12	12	6	870
10-1200	10	1200	72	12	12	6	870
15-1200	15	1200	72	12	12	6	870
20-1200	20	1200	84	15	12	7	1483
25-1200	25	1200	84	15	12	7	1483
30-1200	30	1200	96	15	25	7	1940
40-1200	40	1200	96	15	25	7	1940
50-1200	50	1200	96	15	25	7	1940
60-1200	60	1200	108	16	25	8	2622
75-1200	75	1200	108	16	25	8	3026
40-900	40	900	96	15	25	7	1940
50-900	50	900	108	16	25	8	2622
60-900	60	900	108	16	25	8	2622
75-900	75	900	116	16	25	8	3026

Other dimensions are available. Dimensions may vary depending on application.