

EPIC SCREW PUMPS

A first class product with state-of-the-art screw pump technology

LANDY SCREW PUMPS

In addition to the general characteristics and advantages of screw pumps, the Landy screw pumps are distinguished by:



Full in-house integrated manufacturing

Totally reliable manufacturing schedules and delivery times



Manufactured with permanent lifting eyes and balancing weights



Fully qualified welders

- X-ray or ultrasonic testing available
- Welding shop approval
- AWS/DIN standards



Flanged shafts are monolithically cast nodular cast iron

Use of fully self-aligning bearings

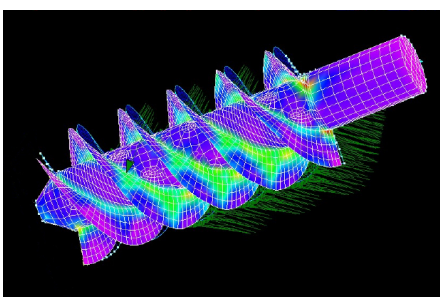

Efficient design

- Usually 2 flights
- Limited deflection
- Limited occurring tension
- High efficiency
- Alternate flight pitch available to maximize efficiency

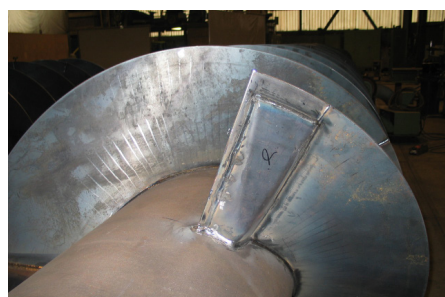

Reinforced leading edges of flights



Surface Preparations – Shot blasting to SP-10 standards

Coating – All required coatings are professionally applied, and can be formulated for extreme environments. Please contact us for severe abrasion, chloride, pH or H₂S applications

Ongoing R&D

Finite Element Analysis standard on all new designs

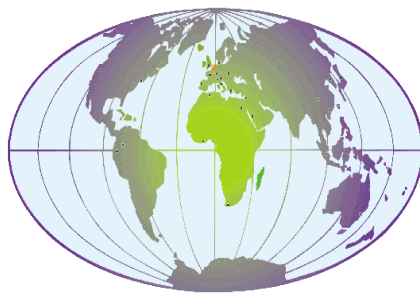

Over 100 years experience

World-wide service with local support

Superb after-sales service

We can offer full supervision of installation



Endplates

- Fully watertight with internal caps over threads of connection bolts
- Precisely parallel and centric manufacture using special lathes

Stainless Steel Screw Pumps are available

PREFABRICATED SCREW PUMP

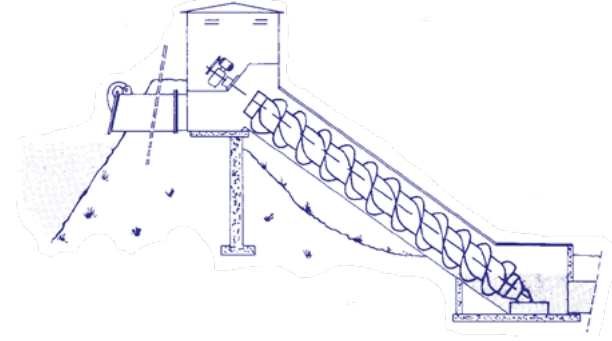

ARCHIMEDEAN SCREW PUMPS

Certified ISO 9001

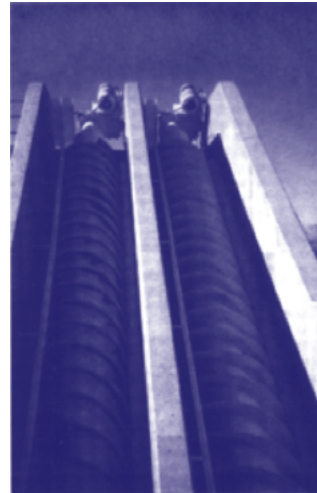

MAXIMUM DESIGN PUMPING CAPACITY

This table is for reference only. Please contact our engineers for specific design selection. These capacities are for three flight screw pumps with maximum pitch, flight radius, and RPM.

DIAMETER	GPM @ 30 °	GPM @ 38 °
16"	460	330
20"	780	570
24"	1,300	940
30"	2,220	1,570
38"	3,390	2,450
42"	4,750	3,450
48"	6,600	4,750
54"	8,800	6,300
60"	11,000	8,700
66"	14,000	10,000
72"	17,200	12,600
78"	21,700	15,300
80"	22,200	15,700
84"	25,400	18,250
90"	30,000	21,600
96"	35,000	25,200
102"	39,800	28,700
108"	45,400	32,700
114"	51,300	37,000
120"	55,500	40,000
158"	108,600	78,400
196" (max)	182,800	131,900

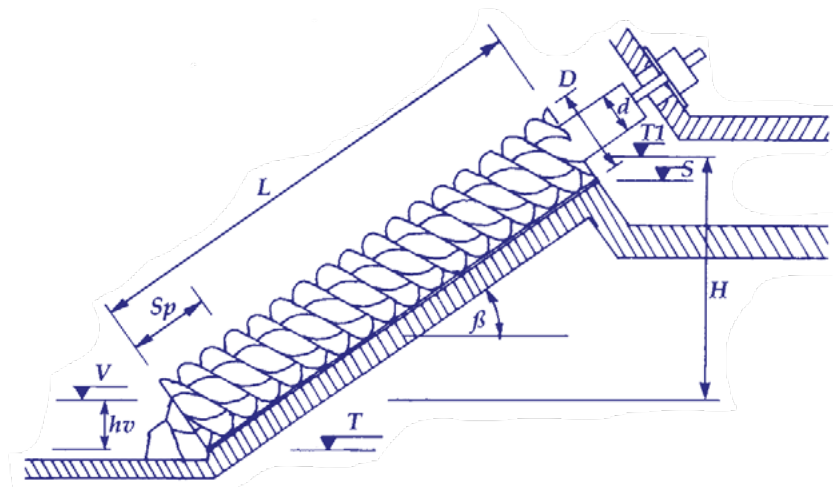

Q Capacity in meters³/sec
 T Touch point
 S Discharge point
 V Filling point
 $T1$ Max upstream water level
 L Length of blades
 Sp Pitch
 D Screw diameter (m)
 d Torque tube diameter (m)
 hv Filling height
 H Static lift in meters
 β Angle of inclination
 N RPM

$H = T1 - V$
 $FLIGHT LENGTH = \frac{(S-T)}{\sin \beta}$
 $MAX RPM = \frac{53}{\sqrt{D^2}}$
 $hv FILL HEIGHT = \frac{D+d}{2} \times \cos \beta$
 $Q = 1.5 \times N \times q \times D^3$
 $N = \frac{Q}{1.5 \times q \times D^3}$
 $POWER (kw) = \frac{981 \times Q \times H}{EFF NET}$

BASIC TECHNICAL DATA

The capacity flowing through the screw pump is a function of the physical parameters of the screw, the speed at which it turns, and the inclination of the screw to the horizontal.

viz. $Q = 1.15NqD^3$
 Where Q = capacity in m³/sec
 q = specific capacity (constant)
 N = RPM
 D = outside diameter of screw in meters
 where d = torque tube diameter in meters

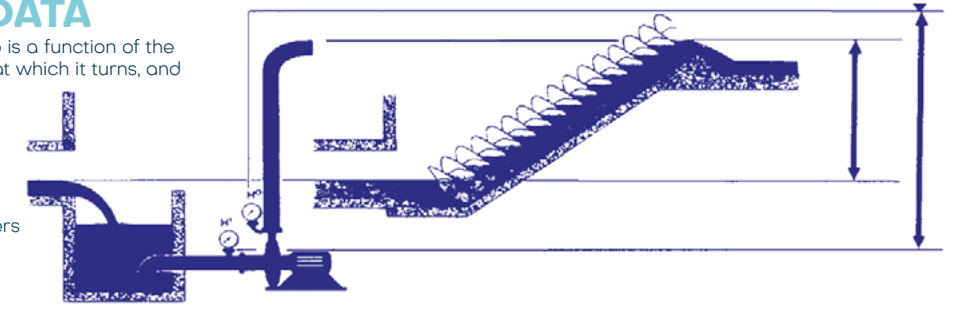

The relationship between Q , N , and D will be obvious and the constant q takes into account the relationship of d/D , the number of flights on the screws and the angle of inclination.

The difference in the design-head requirements between the screw and the centrifugal pump is clearly shown in the above diagram for identical outfall and lift conditions. This difference is a major factor when considering operational costs.

EFFICIENCY/CAPACITY CURVE

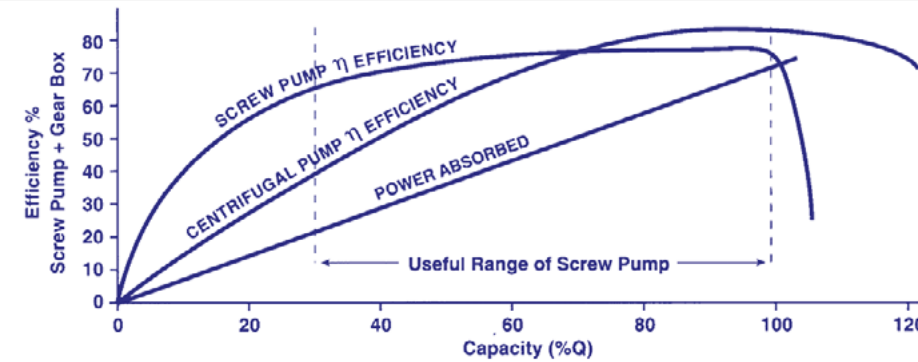

The curve shows

1. that the screw efficiency stays very high even with flows as low as 20-30% of full capacity.
2. the importance of clearly specifying the maximum value to be pumped as the screw cannot deliver a greater volume than that delivered when the water inlet is up to the fill point.

ADVANTAGES OF SCREW PUMPS

- Low wear/low speed
- High efficiency
- Capable of pumping highly polluted liquids
- Automatic priming
- Easily accessible
- Long service life
- Low maintenance
- High reliability
- May rotate in dry condition
- Self regulating
- Simple construction
- Low noise
- Non-clogging

DRIVE UNITS - FIVE MOST COMMON ARRANGEMENTS

1 Top bearing type: floor-mounted

Gear speed reducer type: partially mounted solid shafts

Flexible coupling between gearbox and screw shaft

Motor mounted on top of the gearbox

V-belts between motor and gearbox

Application: all outputs

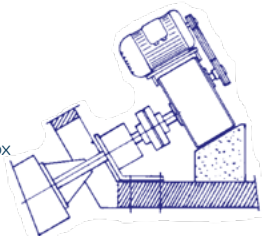

2 Top bearing type: wall-mounted

Gear speed reducer type: shaft-mounted

Motor mounted on top of the gearbox

Application: limited outputs

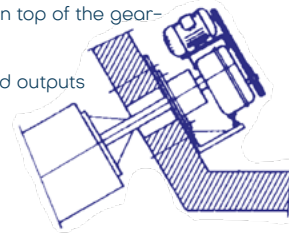

3 Top bearing type: floor-mounted

Gear speed reducer type: shaft-mounted

Motor installed on top of gearbox

Application: 100 HP maximum

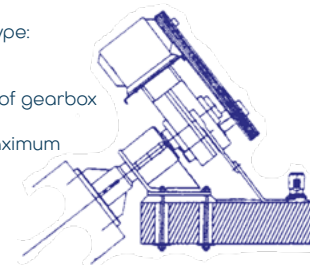

4 Top bearing type: floor-mounted

Gear speed reducer type: parallel mounted solid shafts

Motor directly coupled to the gearbox

Flexible coupling between reducer and screw shaft

Application: all outputs

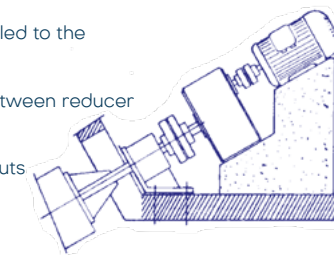

5 Top bearing type: floor-mounted

Gear speed reducer type: parallel mounted solid shafts

Flexible coupling between gearbox and screw shafts

Application: all outputs

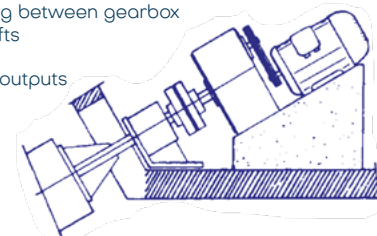

LOWER BEARINGS

Landustrie Screw Pumps are available with four different Lower Bearing designs. The newest and most exciting of which is the permanently lubricated, completely self-contained, and fully self-aligning in all 3 axes, Landy Eco-Friendly system as detailed below.

All our Lower Bearing types carry the radial thrust forces while also accommodating longitudinal expansion and contraction brought by temperature changes. The special merits of all four Landustrie Lower Bearing designs are conveniently outlined in the table on the opposite page. Landustrie bearings can be retrofitted to existing screw pumps by other manufacturers.

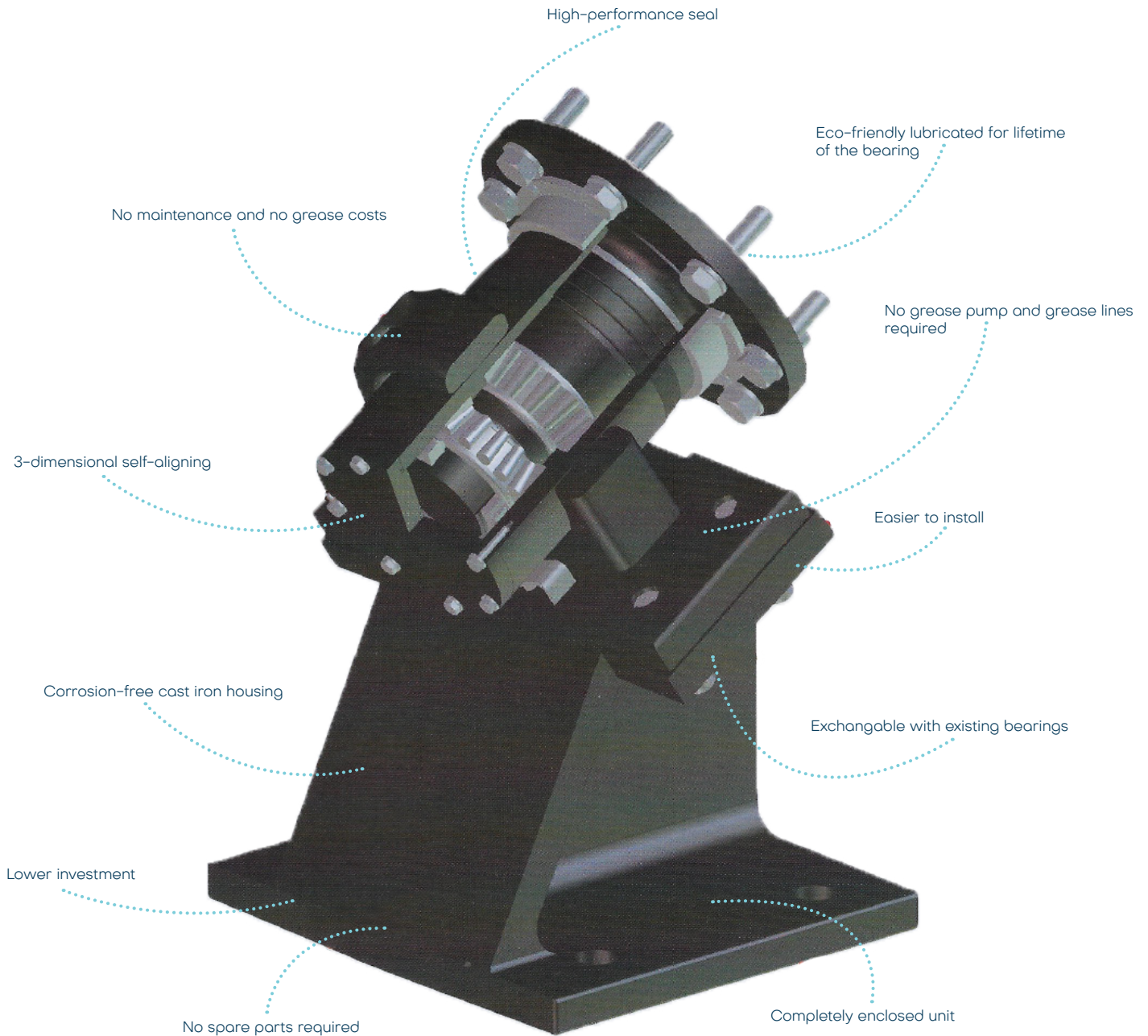

ECO-FRIENDLY LOWER BEARING

LOWER BEARING SELECTION TABLE	Eco-Friendly 	Conventional 	Trunnion Type 
Lubrication	Oil Lubricated	Grease	Grease
Grease filling	NA	Yes	•
Grease return line	NA	On request	•
Maintenance required	5 years	Grease lubrication	Grease
3D self-aligning	•		•
Water quality	Low	Low	Low
Installation time	Low	Average	Low
Heavy duty			•
Exchangeability with existing bearings	•	•	
Investment	Low	Medium	High
Operational costs	Low	Medium	Medium
Lifetime	Long	Long	Longest

UPPER BEARINGS

For the upper bearing EPIC can offer the choice between two different versions; a wall-mounted or a foot-mounted upper bearing. The benefits of the wall-mounted upper bearing are that the forces on the civil construction will be better absorbed, and also that an odor-tight separation

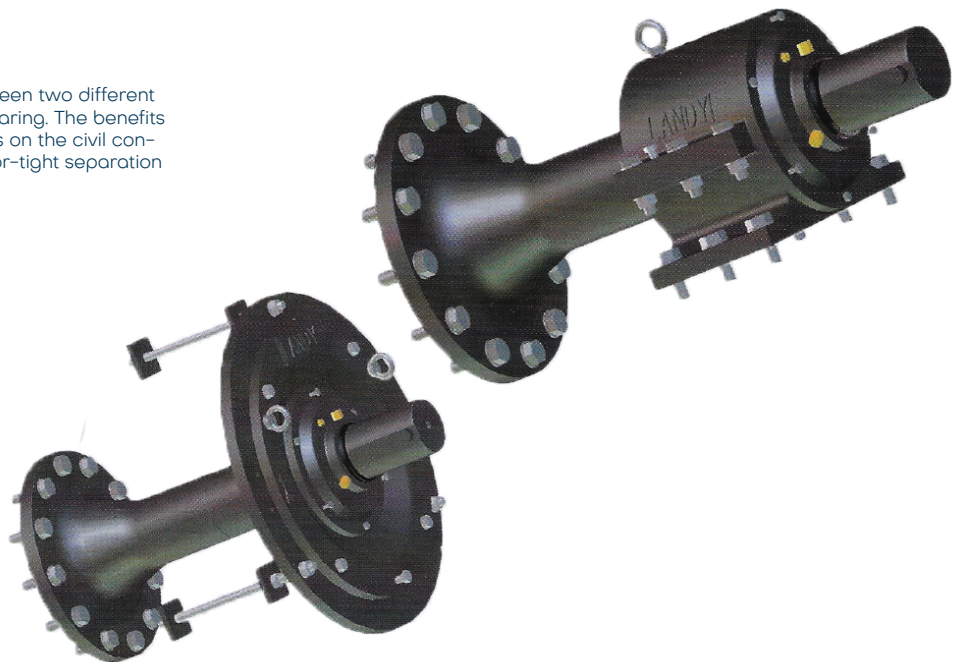

EPIC “FLIGHT DEK” COVERS

On request we can cover the installation with modular, light weight, maintenance free, pultruded FRP covers. Advantages are:

- Protection of the screw pump against thermal expansion
- Creates a safe working environment
- Reduced the levels of noise production



TROUGHS

There are several choices of Screw Pump troughs.

- Conventional, classic concrete, custom grouted by the Screw Pump
- Conventional, classic concrete with removable steel grout casting molds
- Permanently Cast-in steel or stainless steel trough liners
- Pre-fabricated, fully self-supporting 'U' steel trough
- Pre-fabricated Screw Pump in an enclosed 360° tube



RESEARCH AND DEVELOPMENT

For many generations, Landustrie has been actively conducting research to continuously improve Screw Pump performance, efficiency, and longevity.

The newest development in the most recent 10 years of our testing program is the permanently lubricated, fully 3-dimensionally self-aligning, and completely self-contained Edo-Friendly Lower Bearing. In addition, Landustrie now conducts Finite Element Analysis on all our new Screw Pump Designs.

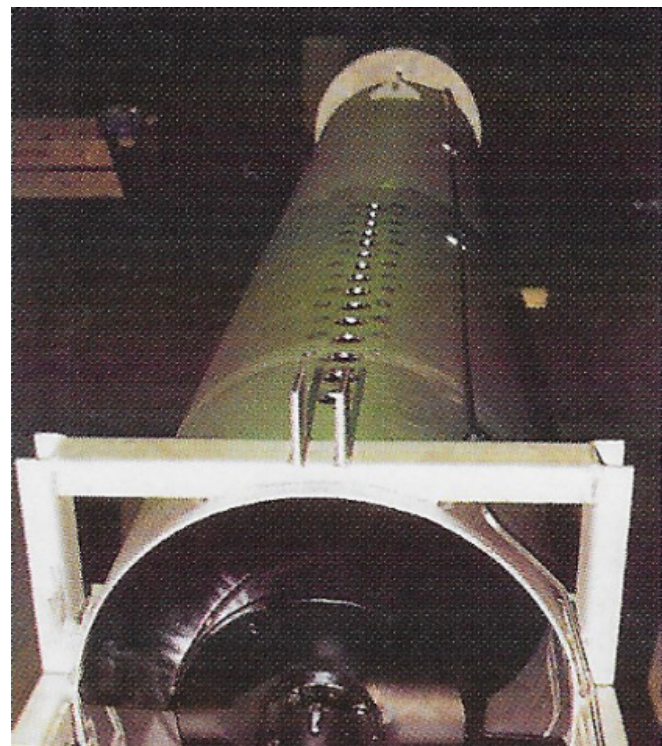

SPECIAL FEATURES OF EPIC SCREW PUMPS

- ISO 9001 certified
- Full penetration welding according to AWS, DIN, ASTM, or API standards
- Internal Bulkheads provide additional watertight fail safe sealing of the Torque Tube
- Endplates are watertight welded with threaded holes for the shaft connections
- Fully self-aligning Upper and Lower Bearing Assemblies
- Monolithic Cast Shafts
- Minimum of two (2) Seals in Lower Bearings
- Separate radial thrust and axial thrust Upper Bearing Assemblies
- Permanent Lifting Eyes built in
- Screed Bar tack welded to top of flights for screeding
- Shot blasting to SA 2.5 (SSPC-SP10) standards
- Prime coating is standard for all parts above and below water level
- Full factory coating under environmentally controlled conditions is recommended
- Reinforced leading edges of the Flights

ADDITIONAL SERVICES & OPTIONAL TESTING

- Ultrasonic Liquid Level Sequential Control System
- Full Submerged Arc Welding
- Left Hand and Right Hand Flights
- Double Lift
- X-Ray Weld Testing
- Ultrasonic Weld Testing
- Torque Tube Air Pressure Testing
- Finite Element Analysis

PARTIAL INSTALLATION LIST (USA)

Mobridge, SD	Coachella, CA	York, PA	St. George, UT	Elkhart, IN
Appomattox, VA	U.S. Army, Ft. Carson CO	Gloucester, MA	Pittsburgh, KS	CA Dept. of Corrections Van Buren, AR
Chelsea, MI	Mineral Wells, TX	Teterboro, NJ	Monett, MO	Dallas Center, IA
Springfield, OH	Fallbrook, CA	Meridian, ID	American Fork, UT	Newnan, GA
Englewood, TN	Emporia, VA	Perryville, MD	Henrico County, VA	Mesquite, NV
Hope Mills, NC	Des Plaines, IL	N. Charleston, SC	HRSD-Newport News, VA	Carthage, MO
Santa Rosa, CA	Barceloneta, PR	Henderson, NV	Caldwell, ID	Logan, UT
Oyster Bay, NY	Salt Lake City, UT	Lubbock, TX	Gilbert, AZ	Ocean County Utilities, NJ
LeRoy, NY	Williamston, MI	Mt. Washington, KY	Sauget, IL	Mountain Home, ID
Indianapolis, IN	Wauseon, OH	Passaic Valley, NJ	USAF, Shaw A.F.B, SC	Fulton, NY
Secaucus, NJ				

Environmental Products for Innovative Conservation

Screw Pumps · Aerators · Mixers · Flight Decks

105 Duncan St.
Ashland, Virginia 23005 USA
epicintl.com
try@epicintl.com
804.798.3939